

# ME 216: Engineering Metrology

## Fundamentals of Geometric Tolerances

**Dr. Suhas S. Joshi**, Department of Mechanical Engineering, Indian Institute of Technology, Bombay, Powai, MUMBAI – 400 076 (India)  
Phone: 91 22 2576 7527 (O) / 2576 8527 ®; [ssjoshi@iitb.ac.in](mailto:ssjoshi@iitb.ac.in)

# Tolerance of Size and Geometry

The tolerance on 'Size' is also called as 'Dimensional' tolerance.

Example –  $\phi 25_{-0.000}^{+0.020}$

But these tolerances may not be sufficient to manufacture the desired fit perfectly. So we require additional tolerances, called 'Geometrical' Tolerances. Example –

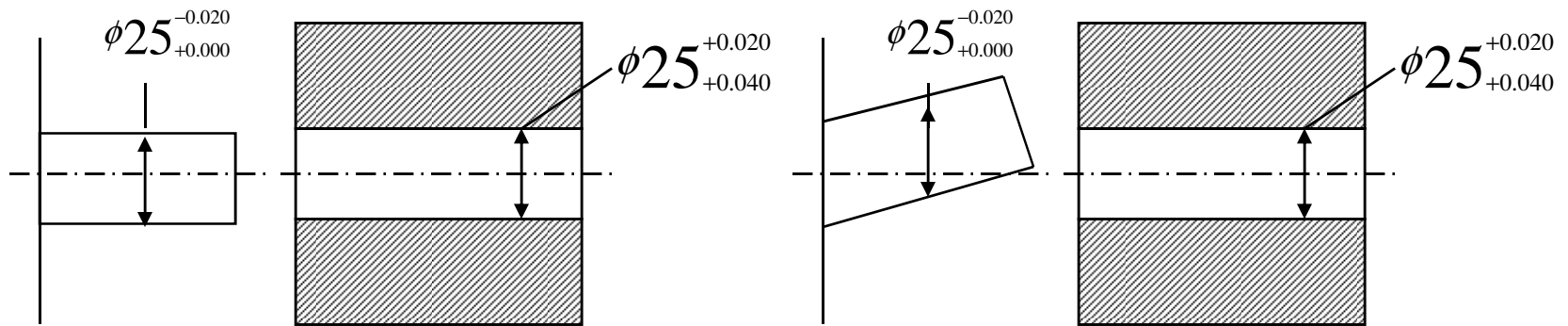

Fit is acceptable, assembly possible  
Parts in Correct **Orientation**

Fit is acceptable, assembly Not possible  
Parts not in correct **Orientation**

# Tolerance of Size and Geometry

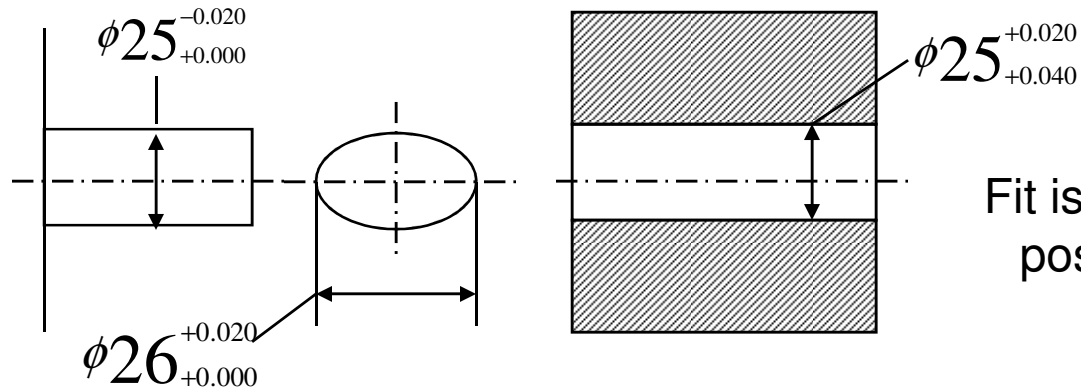

Fit is acceptable, assembly Not possible  
 Parts not in correct **Shape**

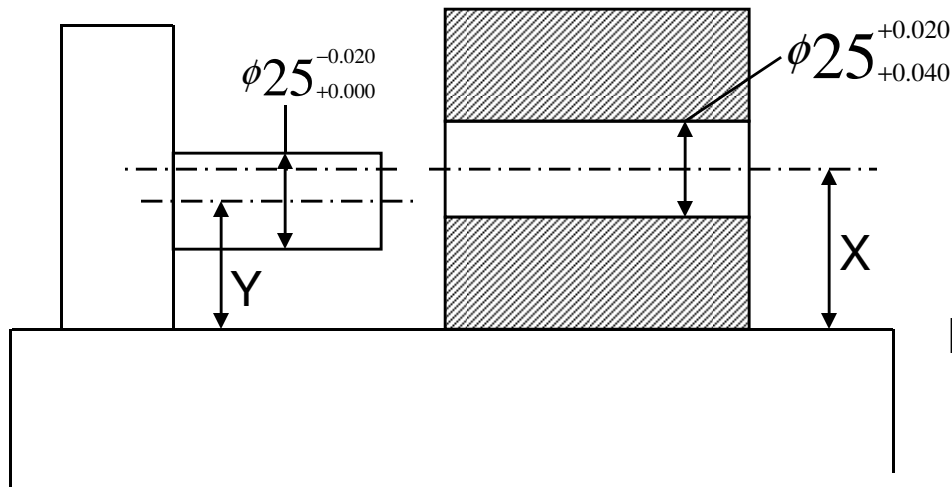

Fit is acceptable, assembly Not possible  
 Parts not in correct **Position**

# Tolerance of Size and Geometry

Therefore, in addition to selecting FIT, it is also important that we specify additional tolerances so that the desired FIT is achieved. These types of tolerances which help specify the functional requirements more clearly, are called as 'Geometrical Tolerances'. These are of following three types –



1. Tolerances on **Shape or Form**
2. Tolerances on **Orientation**
3. Tolerances on **Position**

Symbol	Tolerance Value	Reference datum
--------	--------------------	--------------------

Geometric Tolerance Representation

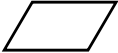
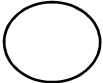
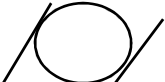

# Geometric Tolerances

## A. Characteristics of Form/Shape



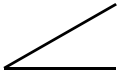

Sr. No.	Characteristics	Symbol
1.	Straightness	
2.	Flatness	
3.	Circularity	
4.	Cylindricity	
5.	Profile of a Line	
6.	Profile of a Surface	

# Geometric Tolerances

## B. Characteristics of Orientation

S. N.	Characteristics	Symbol
1.	Parallelism	
2.	Perpendicularity	
3.	Angularity	

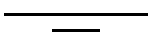
## C. Characteristics of Position

S.N.	Characteristics	Symbol
1.	Position	
2.	Concentricity/Co-axiality	
3.	Symmetry	
4.	Run out	

# Geometric Tolerances

## Straightness

It is the characteristic of a line where all the elements of a line are co-linear. In general, there could be two lines, within which, all the points on a line lie.

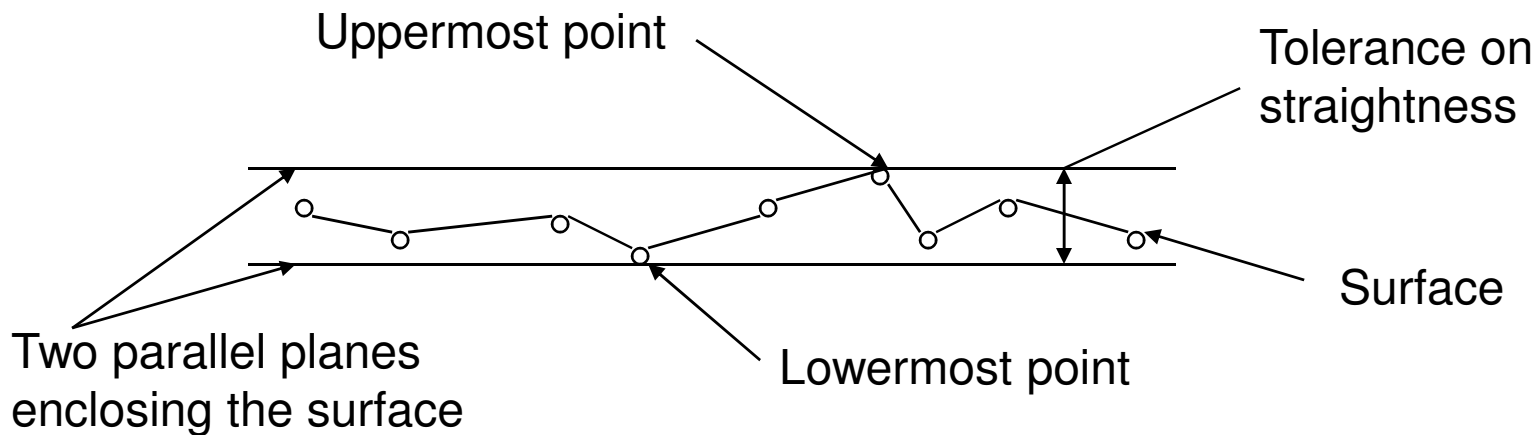

Definition of Straightness

# Geometric Tolerances

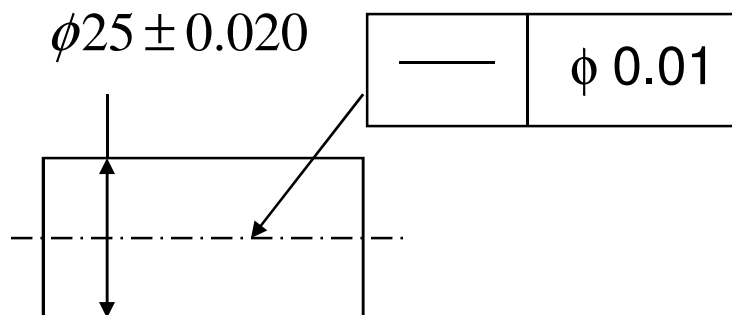

## Concept of Maximum Material Condition

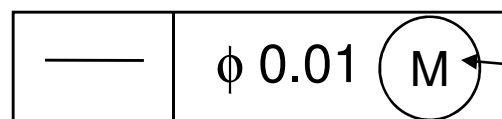

Symbol of Maximum material condition

As the feature size reduces below its MMC, the tolerance goes on increasing as can be seen from the adjoining table.

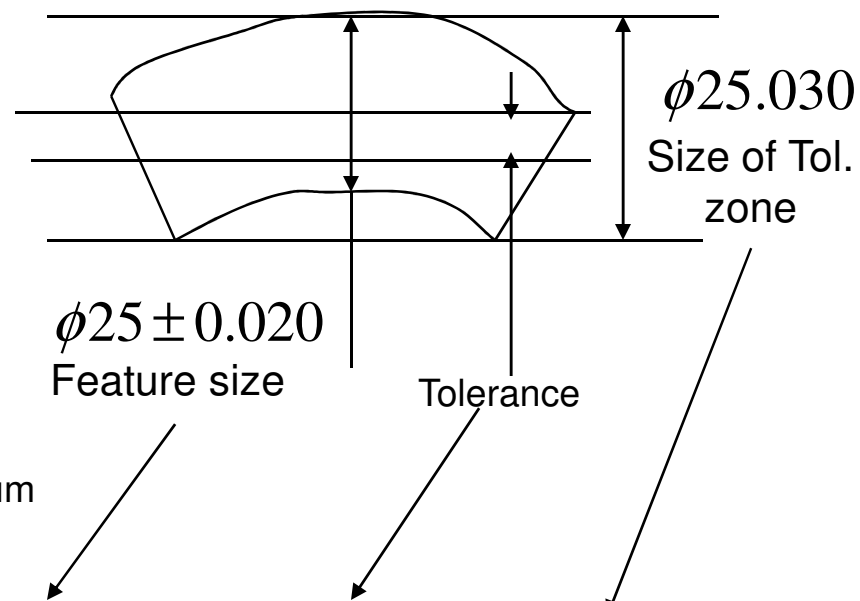

Feature Size	Tolerance	Size of zone
25.020	$\phi 0.01$	25.030
25.010	$\phi 0.02$	25.030
25.000	$\phi 0.03$	25.030
24.990	$\phi 0.04$	25.030



# Geometric Tolerances

## Flatness

It is defined as minimum distance between two planes within which all the points on a surface lie. A surface along which all the points lie along single plane is called as perfectly flat surface.

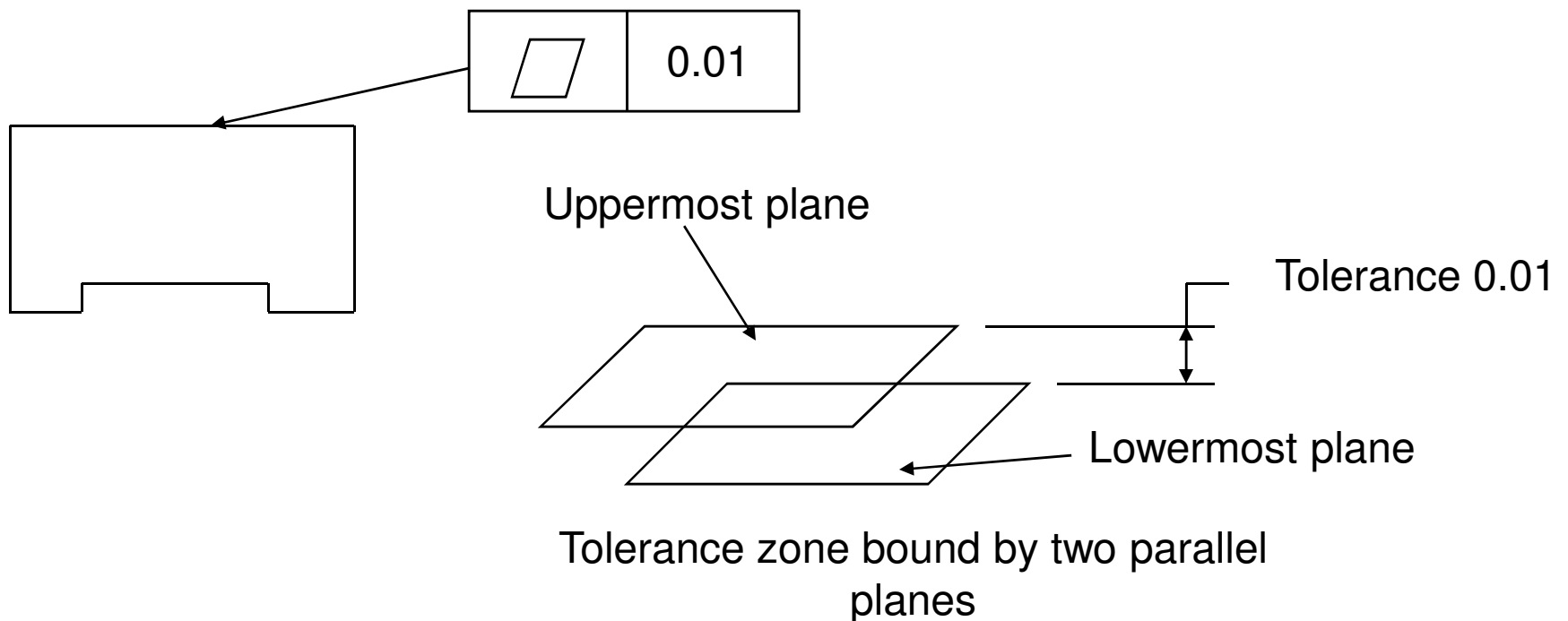

The maximum material condition is not applicable to Flatness

# Geometric Tolerances

## Circularity

It is defined for a cylindrical or conical surfaces. It defines the distance between the surface and its axis.

Ideally, all points on a surface (at a cross-section), should be equidistant from the axis for the cross-section to be perfectly circular.

The tolerance on circularity is defined by two concentric circles within which a surface can lie. The distance between two the concentric circles is called tolerance.

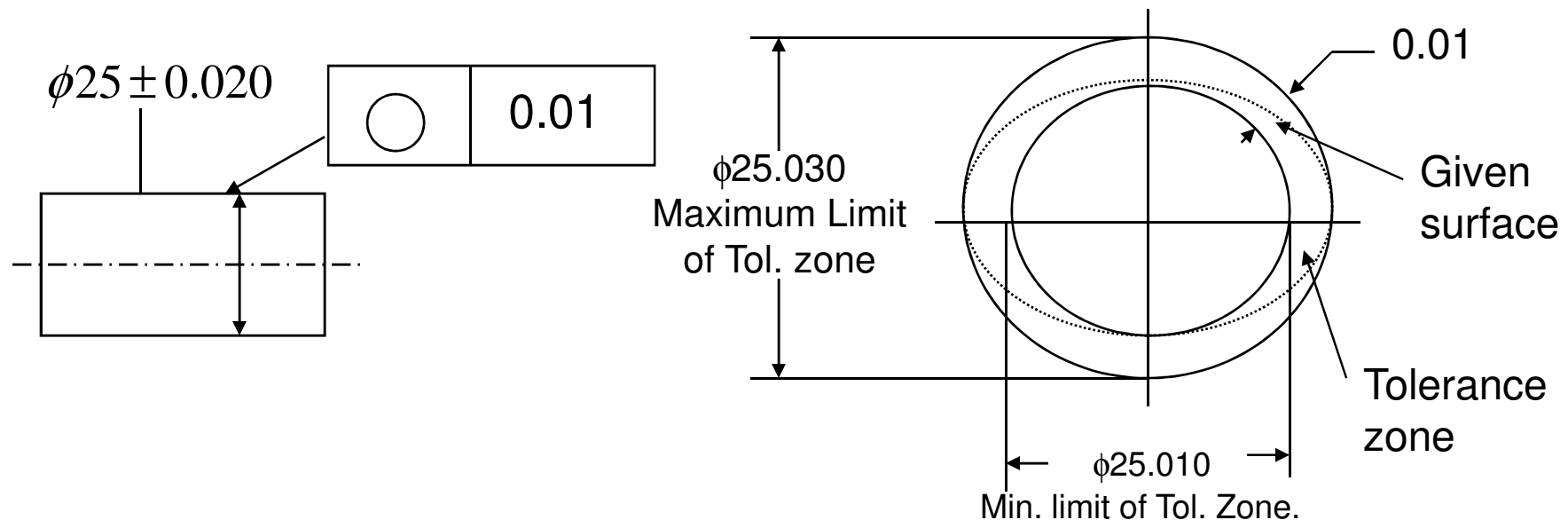

The maximum material condition is not applicable to Circularity

# Geometric Tolerances

## Cylindricity

It is defined for a surface of revolution. It defines the distance between the surface and its axis.

Ideally, all points on a surface (of revolution), should be equidistant from the axis for the cross-section to be perfectly cylindrical.

The tolerance on cylindricity is defined by two concentric cylinders within which a surface can lie. The distance between the two concentric cylinders is called tolerance.

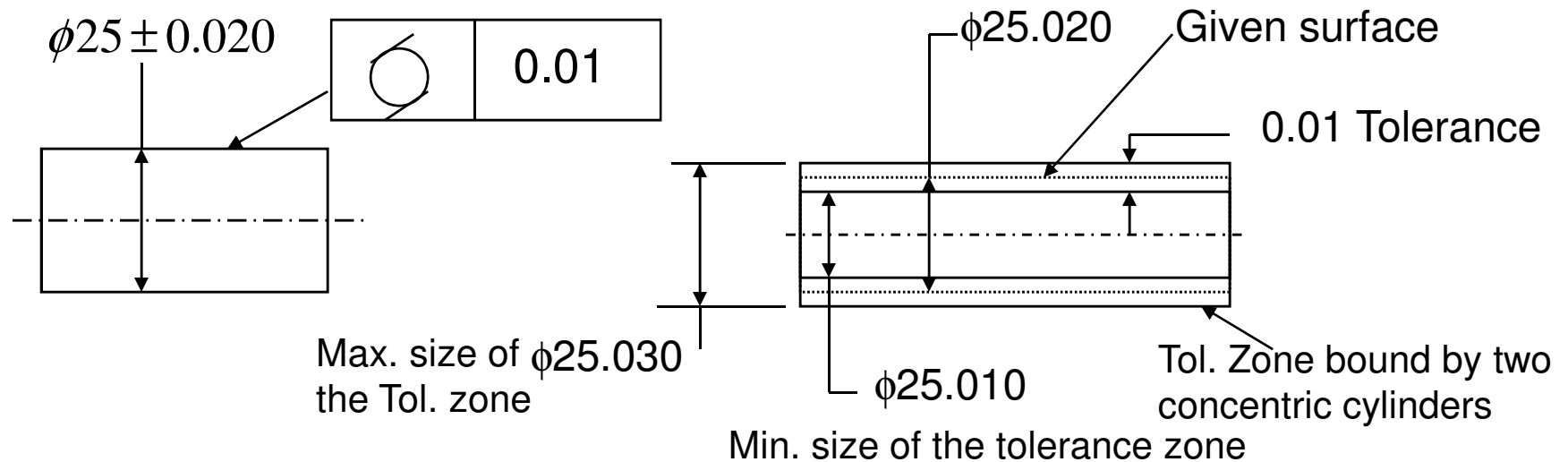

The maximum material condition is not applicable to cylindricity

# Geometric Tolerances

## Profile of Line or Surface

It is defined for a line of any shape or surface of any shape. It defines the distance between two lines or surfaces of the same shape as that of the line or surface in question, separated by a distance equal to tolerance.

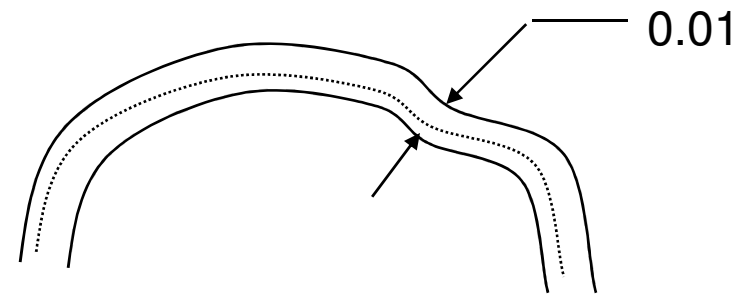
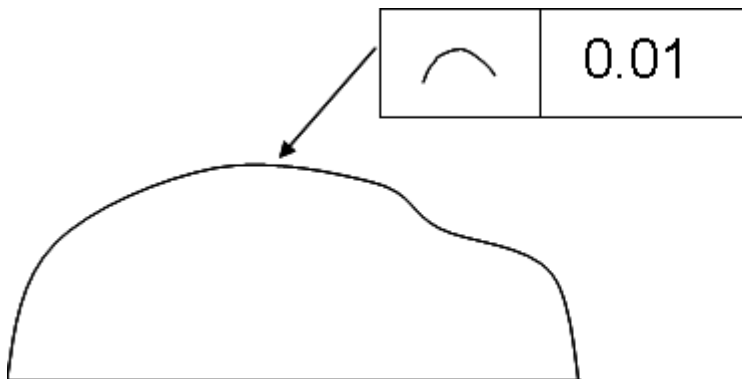
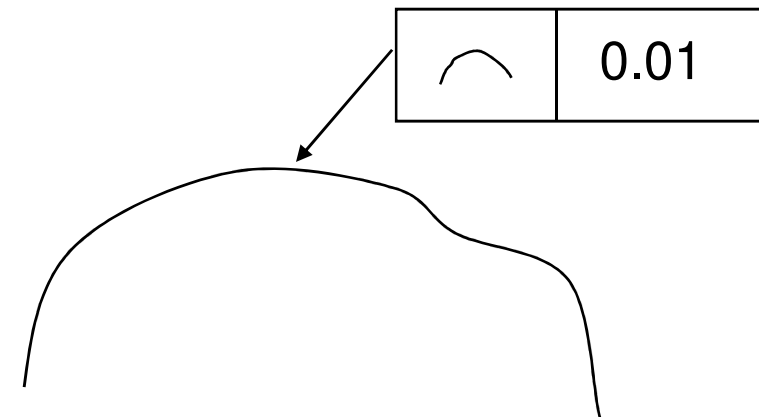

Profile of a line

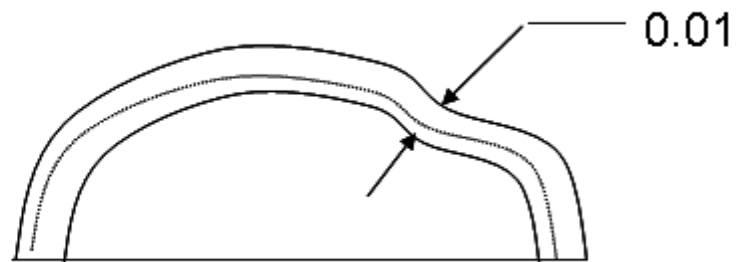

Profile of a surface

# Geometric Tolerances

## Perpendicularity

It is defined for a feature (like surface or line) with reference to another feature called reference. It defines the distance between two lines or surfaces that are parallel to each other and perpendicular to the datum surface and encompass the line or surface in question.

### Perpendicularity of a Line with Surface as datum

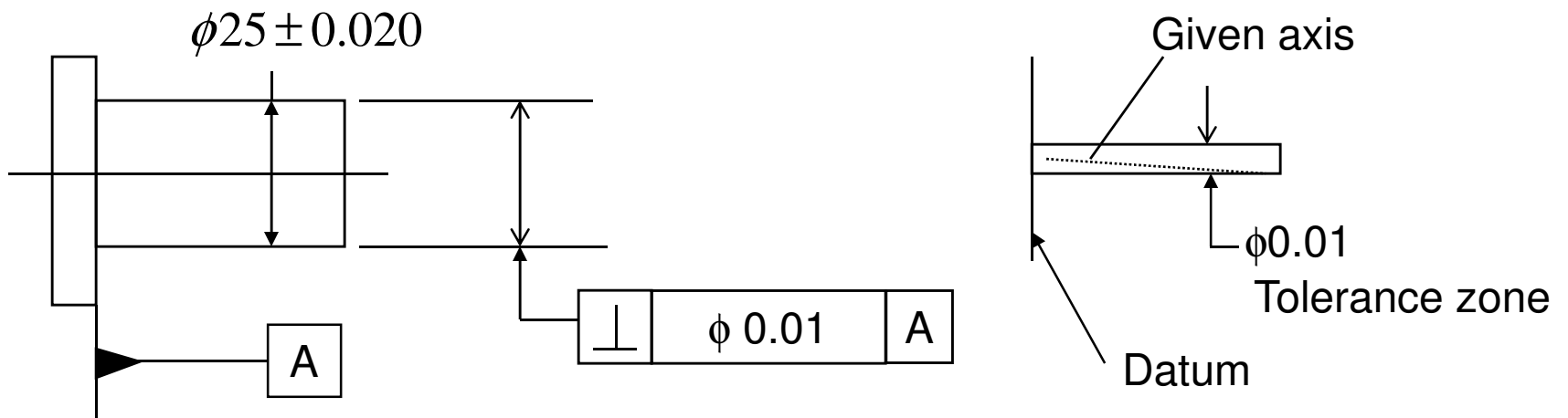

Maximum size of the part = Maximum size permitted by the dimensional tolerance (25.020) + geometrical tolerance (0.01) = 25.03 mm

Minimum size of the part = Minimum size permitted by the dimensional tolerance (24.98) - Geometrical tolerance (0.01) = 24.97 mm

# Geometric Tolerances

## Perpendicularity of a Surface with Line as a datum

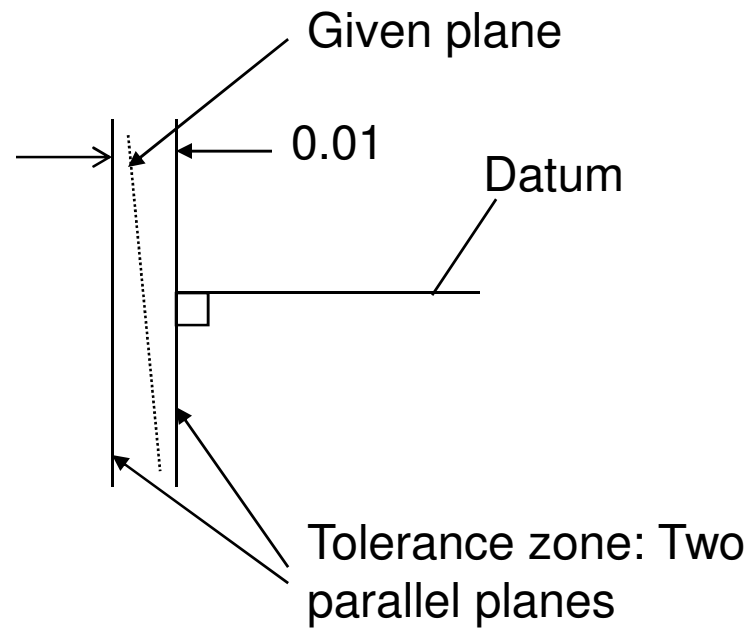
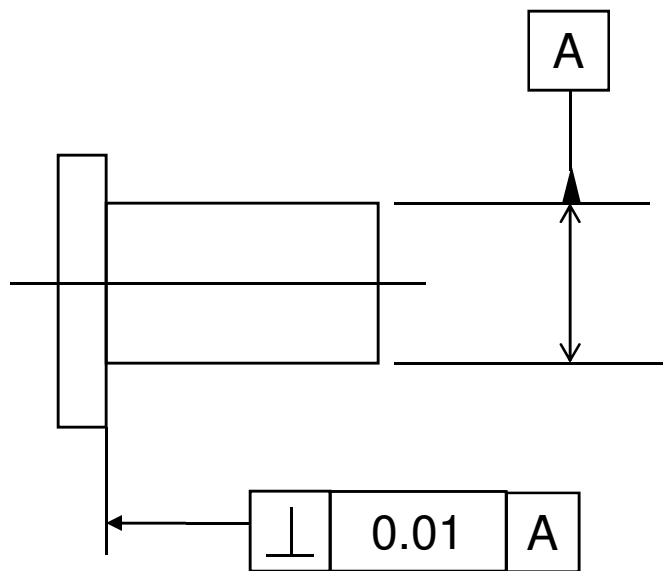

# Geometric Tolerances

## Perpendicularity of a Surface with Surface as a datum

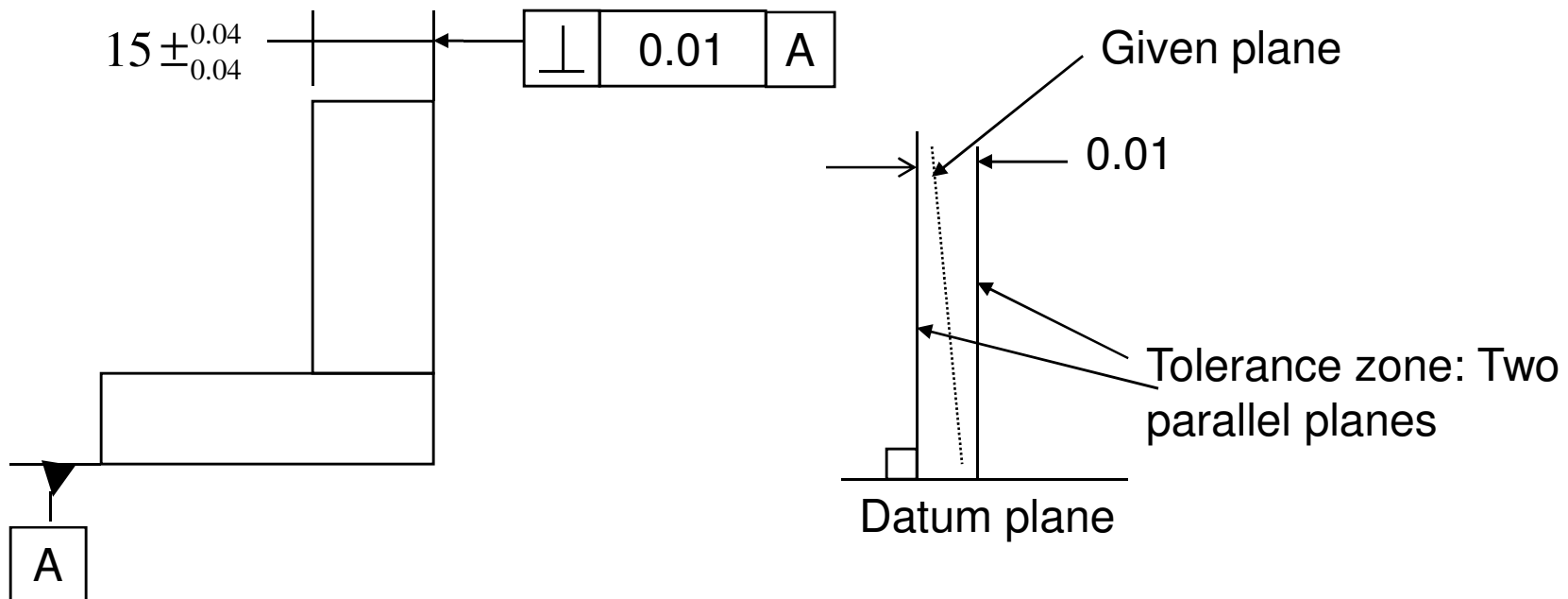

Maximum size of the part = Maximum size permitted by the dimensional tolerance (15.040) + geometrical tolerance (0.01) = 15.05 mm

Minimum size of the part = Minimum size permitted by the dimensional tolerance (14.96) - Geometrical tolerance (0.01) = 14.95 mm

# Geometric Tolerances

## Parallelism

It is defined for a feature (like surface or line) with reference to another feature called reference. It defines the distance between two lines or surfaces that are parallel to each other and parallel to the datum surface and encompass the line or surface in question.

## Parallelism of a Line with Line as datum

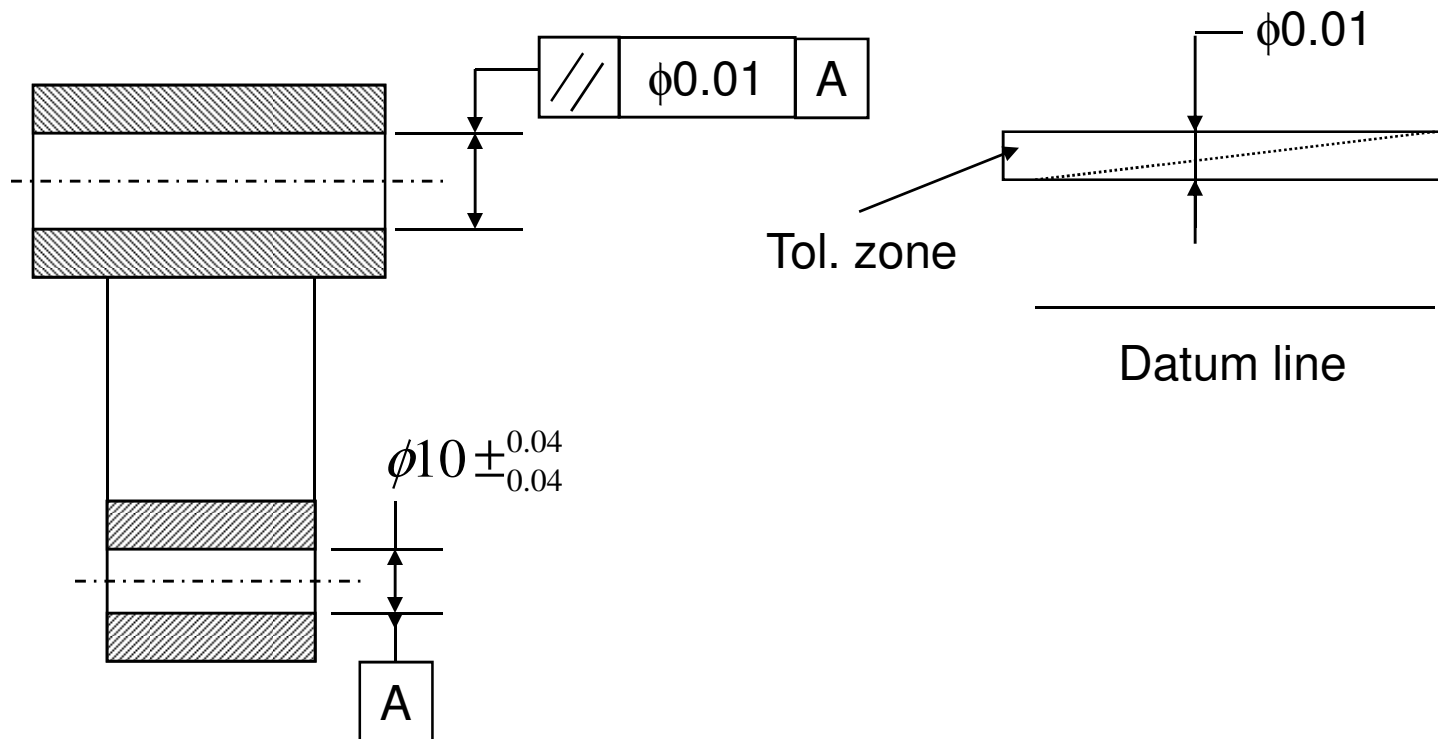



# Geometric Tolerances

## Parallelism of a Line with Line as a datum

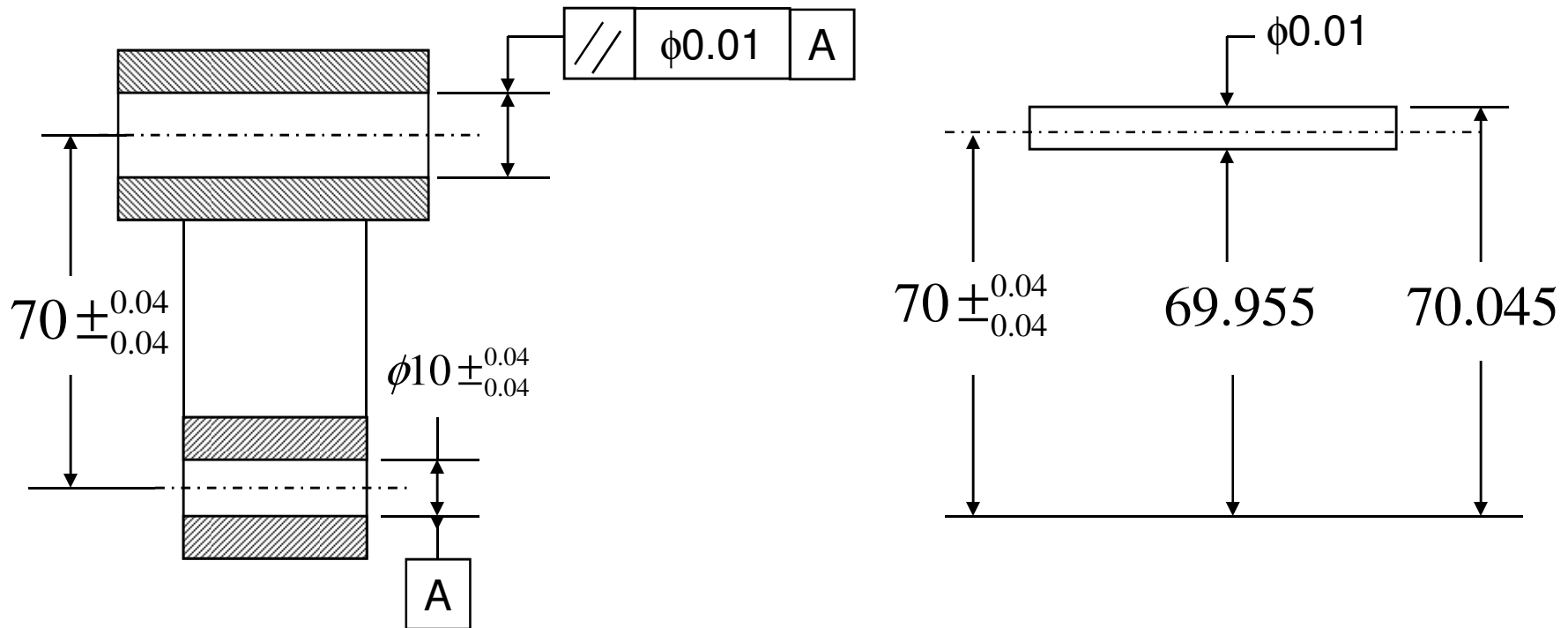

Max. distance between holes = Max distance permitted by the dimensional tolerance  
 $(70.040) + (1/2) \text{ Geometrical tolerance } (0.005) = 70.045 \text{ mm}$

Min. distance between holes = Min. distance permitted by the dimensional tolerance  
 $(69.96) - (1/2) \text{ Geometrical tolerance } (0.005) = 69.955 \text{ mm}$

# Geometric Tolerances

## Parallelism of a Line with Surface as a datum

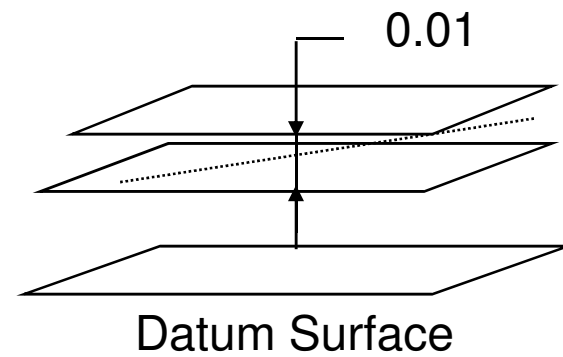
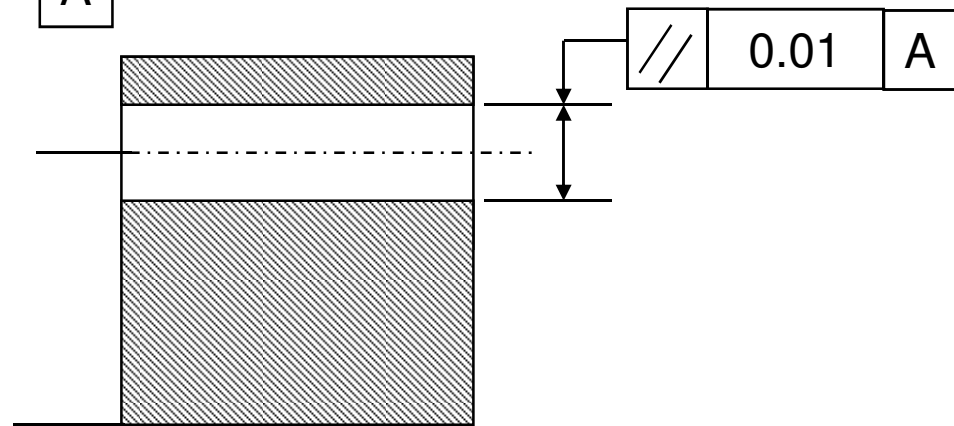
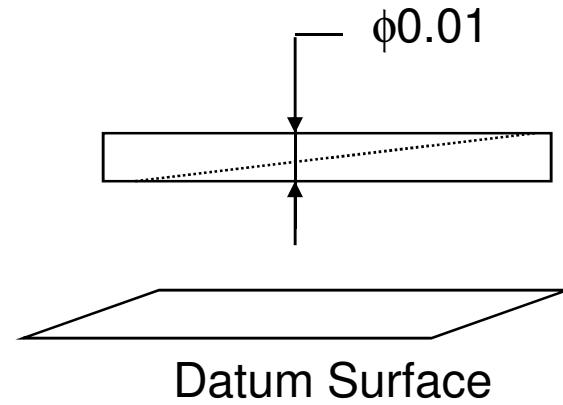
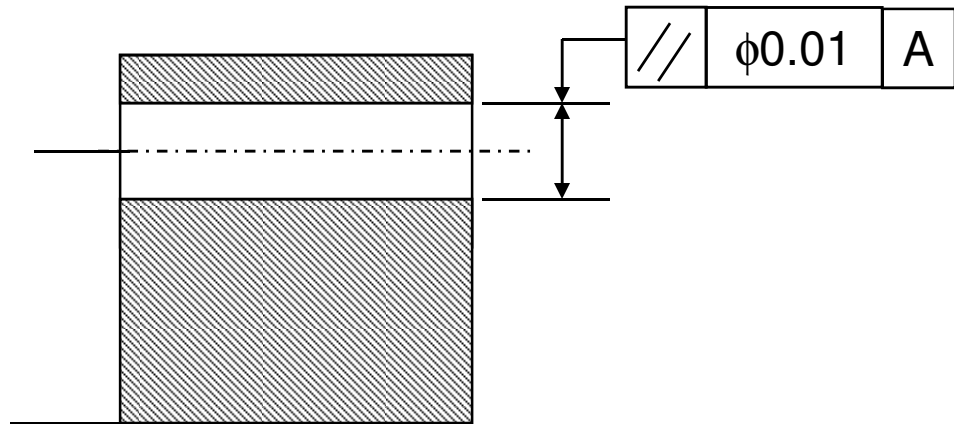

# Geometric Tolerances

## Parallelism of a Surface with Surface as a datum

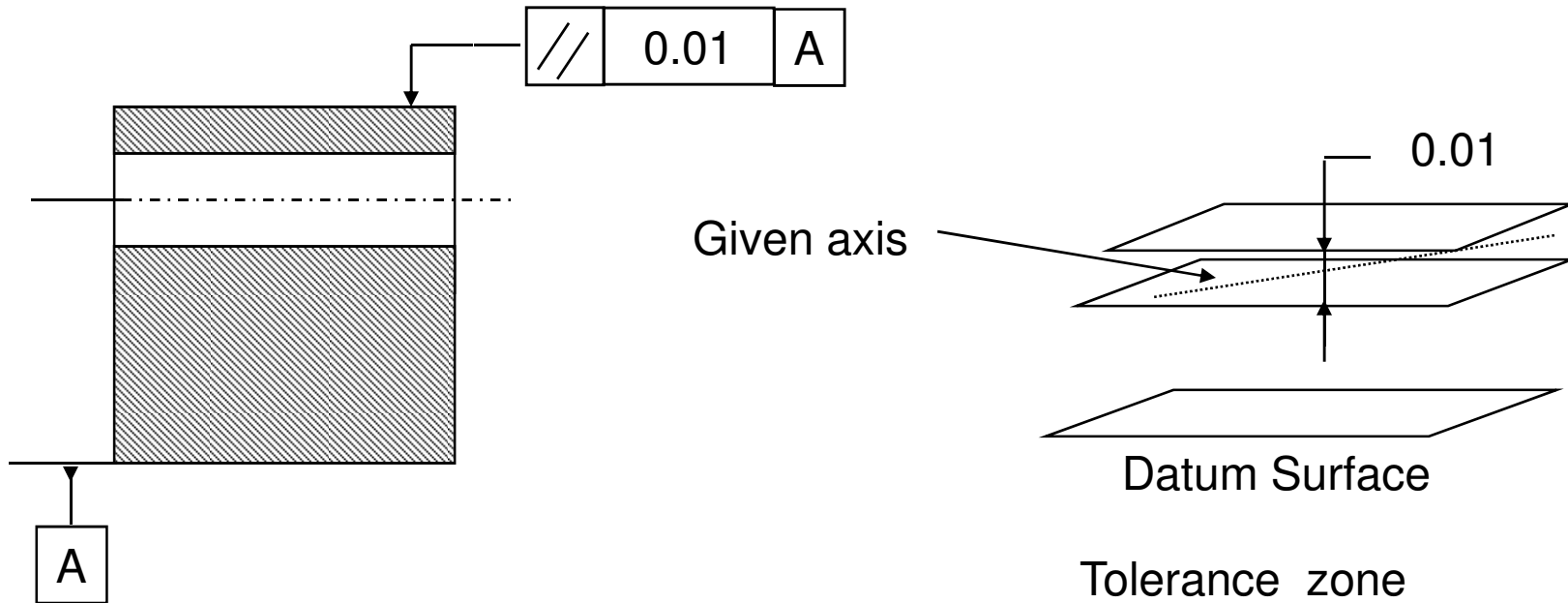

# Geometric Tolerances

## Angularity

It is defined for a feature (like surface or line) with reference to another feature called reference. It defines the distance between two lines or surfaces that are at an angle to the datum surface and encompass the line or surface in question.

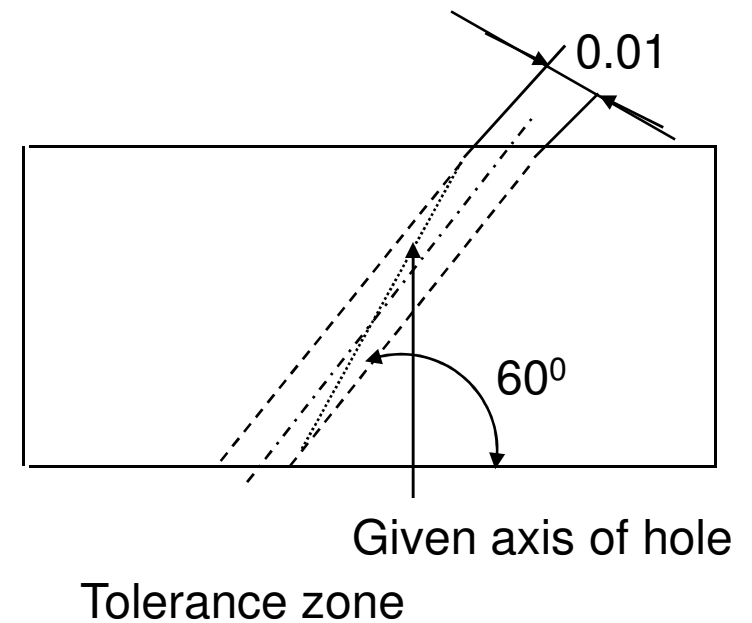
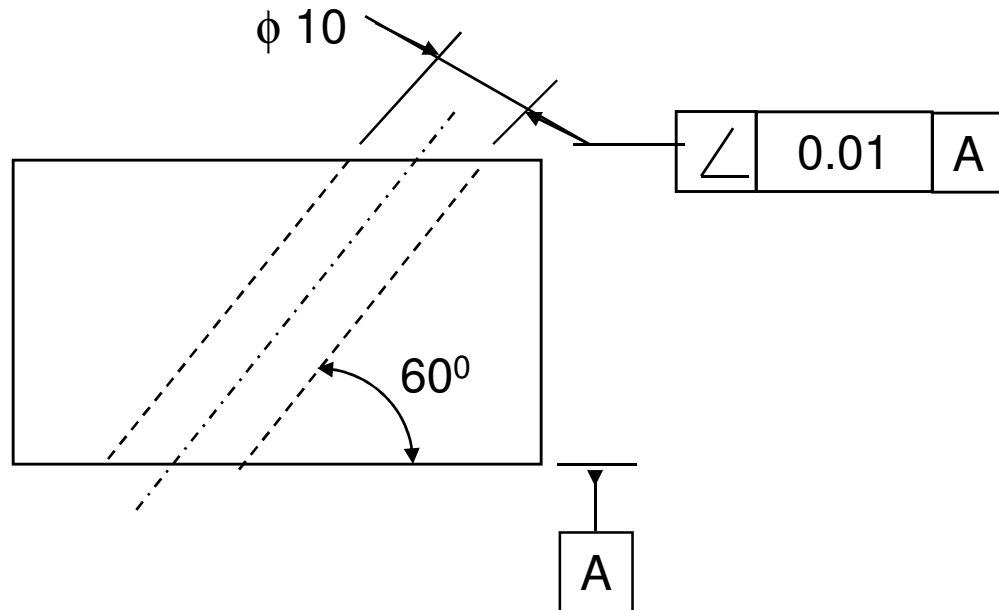

# Geometric Tolerances

## Position

It defines the perfect (exact) location of a point, line or a surface in relation to the other datum

### Position of a line

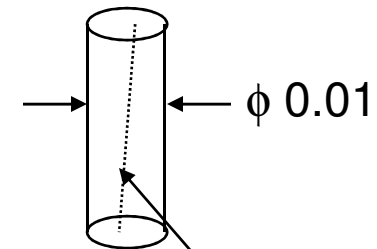
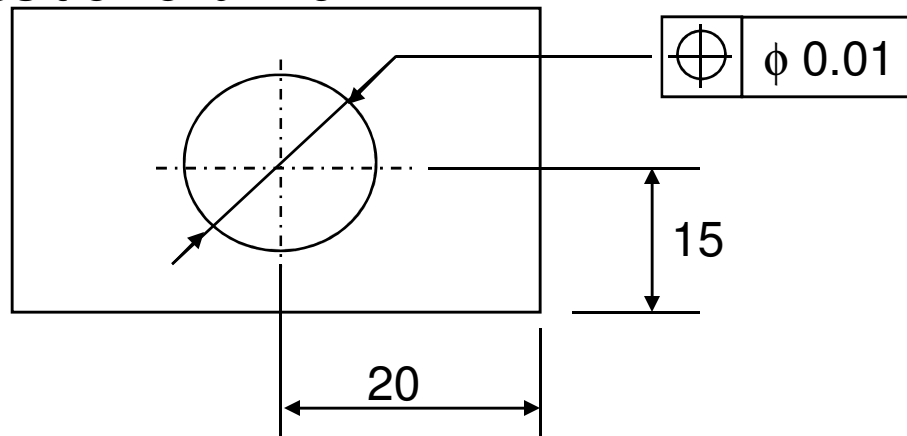

### Position of a line with surface as a datum

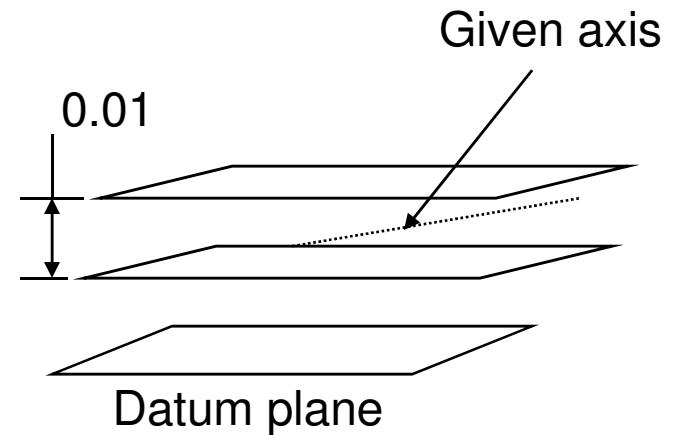
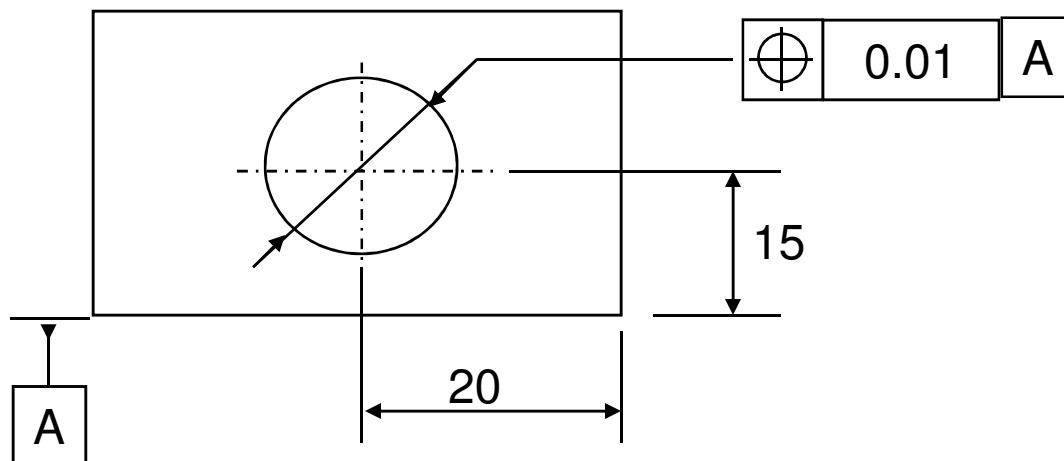

# Geometric Tolerances

## Concentricity

It defines the position of an axis in relation to the other datum axis. It defines a cylinder which coincides with the datum axis and of diameter given by the geometrical tolerance.

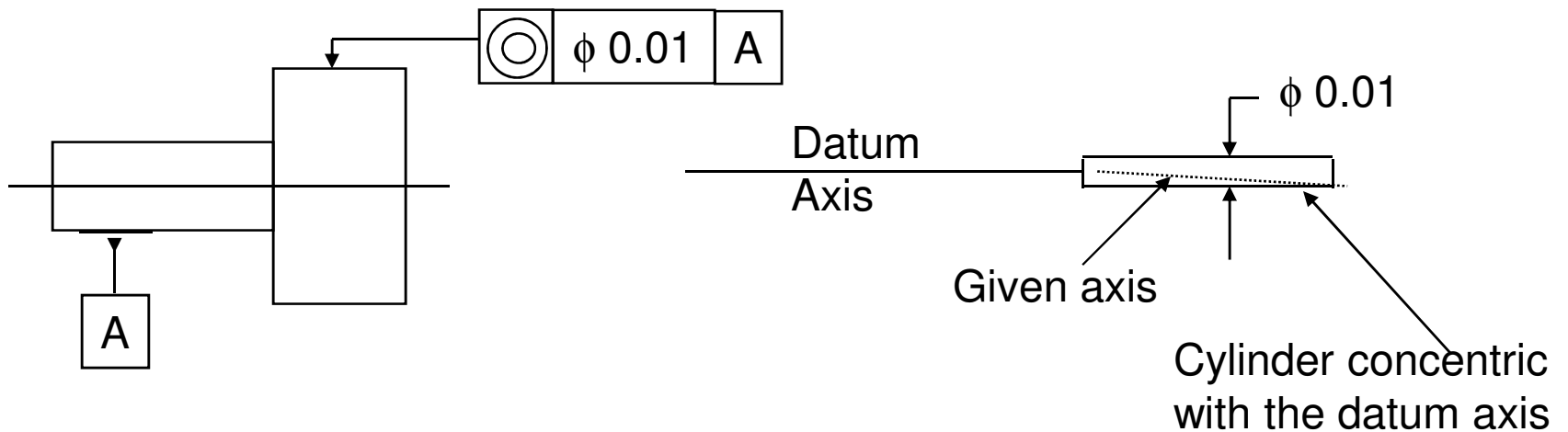

# Geometric Tolerances

## Run out

It defines the deviation from the desired form and orientation during one full rotation of the part on the datum axis.

